

Operations Research on ESP Delivery and Community Clinics in Bangladesh

**Transition Plan on Shift from Outreach to
Community Clinic-based Service-delivery System:
A Study of Perspectives of Stakeholders**

**Sukumar Sarker
Ziaul Islam
Subrata Routh
Rumana A Saifi
Hosne Ara Begum
SM Asib Nasim
M Mesbahuddin**



**ICDDR,B: Centre for Health and Population Research
Mohakhali, Dhaka 1212, Bangladesh**

ICDDR,B Working Paper No. 146

Edited by: M. Shamsul Islam Khan

Design and Desktop Publishing: Jatindra Nath Sarker
Manash Kumar Barua

ISBN: 984-551-231-3

ICDDR,B Working Paper No. 146

©2001. ICDDR,B: Centre for Health and Population Research

Published by:

ICDDR,B: Centre for Health and Population Research

GPO Box 128, Dhaka 1000, Bangladesh

Telephone: (880-2) 8811751-60 (10 lines); Fax: 880-2-8811568

E-mail: msik@icddrb.org; URL: <http://www.icddrb.org>

Printed by: Sheba Printing Press, Dhaka

Acknowledgements

The Operations Research Project (ORP), a project of the ICDDR,B: Centre for Health and Population Research, works in collaboration with the Ministry of Health and Family Welfare, Government of the People's Republic of Bangladesh, and is supported by the United States Agency for International Development (USAID).

This publication was supported by the USAID under the Cooperative Agreement No. 388-A-00-97-00032-00 with the ICDDR,B. The Centre is supported by the following countries, donor agencies, and others who share its concern for the health and population problems of developing countries:

- Aid agencies of governments of: Australia, Bangladesh, Belgium, Canada, European Union, Japan, the Netherlands, Norway, Saudi Arabia, Sri Lanka, Sweden, Switzerland, the United Kingdom, and the United States of America
- UN agencies: International Atomic Energy Agency, UNAIDS, UNICEF, and WHO
- International organizations: CARE Bangladesh, International Center for Research on Women, International Development Research Centre, Swiss Red Cross, and World Bank
- Foundations: Ford Foundation, George Mason Foundation, Novartis Foundation, Rockefeller Foundation, and Thrasher Research Foundation
- Medical research organizations: Karolinska Institute, National Institutes of Health, New England Medical Center, National Vaccine Programme Office, Northfield Laboratories, Procter and Gamble, Rhone-Poulenc Rorer, and Walter Reed Army Institute for Research-USA
- Universities: Johns Hopkins University, London School of Hygiene & Tropical Medicine, University of Alabama at Birmingham, University of California at Davis, University of Göteborg, University of Maryland, University of Newcastle, University of Pennsylvania, and University of Virginia
- Others: Arab Gulf Fund, Futures Group, International Oil Companies (Cairn Energy PLC, Occidental, Shell, Unocal), John Snow International, Pathfinder International, UCB Osmotics Ltd., and Wander AG

The authors place on record their sincere gratitude to Mr. Muhammed Ali, Chief Advisor, Management Change Unit, Mr. Md. Waliul Islam, Team Leader, Programme Coordination Cell, Ministry of Health and Family Welfare (MOHFW), Dr. A.M. Zakir Hussain, former Director, Primary Health Care and Disease Control, and Line Director, ESP (H), Directorate General of Health Services, and Dr. Jahiruddin Ahmed, former Director, MCH-Services, and Line Director, ESP (RH), Directorate of Family Planning, for their continued support and guidance in preparation of the report. Special thanks go to Dr. Enamul Karim, Deputy Team Leader, Health and Life Sciences Partnership and Senior Consultant, Management Change Unit, MOHFW for his valuable comments and suggestions on the study. And finally, we acknowledge the useful inputs of community people, service providers, supervisors, and managers who have actively participated in the process of developing the report.

Glossary

AHI	Assistant Health Inspector
ANC	Antenatal Care
BCC	Behaviour Change Communication
CC	Community Clinic
CG	Community Group
CPR	Contraceptive Prevalence Rate
EPI	Expanded Programme on Immunization
ESP	Essential Services Package
FP	Family Planning
FPI	Family Planning Inspector
FWA	Family Welfare Assistant
FWV	Family Welfare Visitor
GoB	Government of Bangladesh
HA	Health Assistant
HI	Health Inspector
HPSP	Health and Population Sector Programme
MCU	Management Change Unit
MIS	Management Information System
MO	Medical Officer
MOHFW	Ministry of Health and Family Welfare
MO-MCH	Medical Officer-Maternal and Child Health
NIPHP	National Integrated Population and Health Programme
PCC	Programme Coordination Cell
PNC	Postnatal Care
RMO	Resident Medical Officer
SC	Satellite Clinic
TB	Tuberculosis Bacillus
UFHPO	Urban Family Health Programme Officer
UFPO	Upazila Family Planning Officer
UHC	Upazila Health Complex
UHFWC	Union Health and Family Welfare Centre
UMIS	Unified Management Information System
UP	Union Parishad
USAID	United States Agency for International Development

Table of Contents

	Page
Summary	v
Introduction	1
HPSP: The Reformative Initiative	1
The Existing Service-delivery System in the Public Sector	2
ESP Delivery in HPSP	5
Transition Plan	6
Objectives	8
Research Questions	9
Materials and Methods	9
Results and Discussion	11
Phase-out of Outreach Centres	11
Workshop at Mirsarai	14
Workshop at Abhoynagar	14
Support Activities	14
Targeted Home Visits	15
Service-delivery for Pocket Population	16
Lessons Learned	17
Recommendations	18
Conclusion	26
References	27
 Figures	
Fig. 1. Existing service-delivery system at the grassroots level	4
Fig. 2. ESP delivery system in rural area	5
Fig. 3. Reorganized plan for service-delivery at the grassroots level.....	6
Fig. 4. Shift in service-delivery strategy.....	7
 Tables	
Table 1. Distribution of workshop participants by profession	10
Table 2. Phase-out plan of the existing outreach centres	11
Table 3. Distribution of EPI outreach sites/satellite clinics for phase-out in phases	13
Table 4. Support activities for the phase-out plan	15

Boxes

Box 1. Transition plan on shift from outreach to CC-based service-delivery system (Plan A) 20

Box 2. Transition plan on shift from outreach to community clinic-based service-delivery system (Plan B)..... 23

Annexures

Annexure 1. Participatory Rural Appraisal 28

Annexure 2. Schedule of Workshop on Development of Transition Plan for Community Clinics 29

Annexure 3. Questions for Discussion on Development of Transition Plan on Shift from the Existing System to the CC-based Service-delivery System 30

Annexure 4. Worksheet for Planning: Phase-out of Satellite Clinics and EPI Outreach Sites within Community Clinic Catchment Area..... 31

Annexure 5. Chart A: Critical activities for implementation of transition plan (Plan-A) on shift from outreach to CC-based service-delivery system..... 34

Annexure 6. Chart B: Critical activities for implementation of transition plan (Plan-B) on shift from outreach to CC-based service-delivery system..... 35

Summary

To meet the changing essential family-health needs, countries across the globe are approaching toward cardinal changes in the health sector for an integrated delivery of basic healthcare. The Health and Population Sector Programme (HPSP) 1998-2003 in Bangladesh was formulated to meet such a need. Over the last two decades, the health and family planning programme of Bangladesh made remarkable strides in reducing fertility and child mortality. But the progress was inadequate with respect to maternal mortality and morbidity. Moreover, the present health service-delivery system does not allow clients to receive integrated child health, reproductive health, including family planning, and other essential family-health services from a particular outlet.

Both HPSP and USAID-funded National Integrated Population and Health Programme (NIPHP): 1997-2002 are aimed at providing a wide range of health and family-planning services through one-stop clinics, capable of delivering an Essential Services Package (ESP), to address the needs of clients better, especially those of the vulnerable groups, i.e. women, children, and the poor. The main purpose of ESP delivery in the HPSP is to organize services, provided at different levels, in a way that they are adequately responsive to the needs of population, and are cost-effective, easier to manage, and convenient for clients/patients. At the grassroots level, the ESP has to be delivered in an integrated way from the static centres, called Community Clinics (CCs), each built for an average population of 6,000. The delivery of ESP involves reorganization and restructuring of the existing service-delivery strategies from the existing home-visitation and makeshift outreach facilities (community outlet approach) to a static centre-based service-delivery.

The primary concern that evolved as the most critical in implementing the HPSP is operationalization of CCs with all the related reorganization and restructuring issues being addressed properly. This paper has addressed the practical ways of implementing the new healthcare-delivery system, particularly the issues and concerns relating to the transition of services, including phasing out of the existing community-based makeshift service-delivery outlets, i.e. EPI outreach sites and Satellite Clinics (SCs). Although the government guideline on implementation of HPSP (Programme Implementation Plan) describes, in general term, the phasing-out process of the existing EPI outreach sites and SCs, details of the entire process were not specified in it.

As part of operations research on ESP delivery and CCs, it was imperative to identify appropriate strategies to address the transitional issues for operationalization of CCs.

The study followed a qualitative approach of participatory discussions with Community Group (CG) members, workers of non-government organizations (NGOs), volunteers, teachers, other elected community representatives, community-level service providers, and union-level supervisors. Four workshops were held during February-March 2000 with participants from four unions of two upazilas, namely Mirsarai upazila in Chittagong district and Abhoynagar in Jessore district. The participants formulated a strategy to plan the gradual phase-out of the existing community-based outreach services. The EPI outreach sites/satellite clinics, located within 10-15 minute walking distance from the CCs would be closed in the first phase, immediately after the CCs start functioning. The EPI outreach sites and SCs, located further away (beyond 15-minute walking distance) from CCs, would be continued for 3-4 months from the date of opening of a CC.

Discussions in the workshops revealed that effective implementation of phase-out of the existing service-delivery sites depends on certain activities to be carried out by the

providers and the community members to support the plan. In the workshops, behaviour change communication activities were identified as the most important support activities. Although the CC-based service-delivery system will eventually replace the existing makeshift service centres and domiciliary visits, a provision for targeted/limited home visits has been made in the government guideline on CCs as a special arrangement to address the needs of the most vulnerable sub-populations unable to attend the CCs on physical ground or other valid reasons. From the participatory approach followed in this study, some issues important for planning the targeted home visits during the transition period also emerged. Based on analysis of the existing situation of the service-delivery system and the issues relating to their use by the rural communities, some useful recommendations have been made for consideration while developing a transition plan in shifting toward the CC-based service-delivery strategy.

The transition plan suggested in this paper is based on the results of participatory workshops with the stakeholders; the plan was not field-tested. It is, therefore, important that, before its nation-wide implementation, its effects are intensely monitored in some experimental sites, and are documented appropriately to make necessary modifications, as may emanate from the field experiences.

Introduction

Over the years, health has been increasingly considered as an important goal of national development. Development is an instrument to improve human welfare, and health is an essential end of development. To reach the goal, countries across the globe are approaching toward purposeful and fundamental changes in the health sector. The realization has brought to the fore that appropriate health policies are needed for sustained development. The Health and Population Sector Programme (HPSP): 1998-2003 in Bangladesh was formulated to meet such need. The present document suggests recommendations on reorganization of the rural health service-delivery system of the country as envisaged in the HPSP.

HPSP: The Reformative Initiative

Over the last two decades, the health and family planning programme of Bangladesh has achieved a remarkable success in reducing fertility and child mortality. The progress is, however, inadequate with respect to maternal mortality and morbidity. Other issues of concern include cost-effectiveness, sustainability, quality of services, and low use of public facilities at the upazila (sub-district) level and below. Moreover, the present healthcare system is fragmented, and does not allow clients to receive integrated health, reproductive health, and family-planning services from a particular outlet.

In the context of the above-mentioned scenario, the Government of Bangladesh has formulated new strategies for the health and population sector to address structural inefficiency and inadequacy in service-delivery. The five-year HPSP is aimed at increasing the range, quality and effectiveness of services.

The HPSP has been initiated to strengthen the healthcare-delivery system through reducing inefficiencies in the management of services and introducing a sector-wide management policy. Both HPSP and USAID-funded National Integrated Population and Health Programme (NIPHP): 1997-2002 are aimed at providing a wide range of health and family-planning services through an effective and financially sustainable system capable of delivering an Essential Services Package (ESP) to be responsive to the needs of clients, especially to those of the vulnerable groups, i.e. women, children, and the poor. The main purpose of ESP delivery is to organize services, provided at different levels, in a way that they meet the needs of population, and are cost-effective, easier to manage, and convenient for clients/patients. It is also intended to provide 100% coverage to the population (1). Within the overall context of the HPSP, the elements of the ESP are grouped into five areas:

- a. Reproductive healthcare, including family planning
- b. Child healthcare
- c. Communicable diseases control
- d. Limited curative care
- e. Behaviour change communication

The ESP has to be delivered as a one-stop service package from static centres and with a client-oriented approach. At the rural community level, the ESP is planned to be delivered through a three-tiered static centre-based government service-delivery system. At the lowest level, the ESP will be delivered in an integrated way from the newly-introduced static centres, called Community Clinics (CCs), each built for an average population of 6,000 (2). The delivery of ESP involves restructuring of the existing service-delivery strategy from the current home-visitation and makeshift community outlet approach to a static centre service-delivery (1). The delivery strategy also includes involvement of the communities in planning and management of

services. The primary concern, thus, evolved as the most critical in implementing the HPSP, is the operationalization of CCs with all the related reorganization and restructuring issues being addressed properly. It is important to note that the CCs will initiate the departure from the domiciliary service-delivery that has been in operation in Bangladesh for the last two decades or more (1).

This paper has addressed some practical ways of implementing the new healthcare-delivery system, particularly the issues and concerns relating to the transition period when the existing community-based makeshift service-delivery outlets (EPI Outreach Sites and Satellite Clinics) would be gradually phased out.

The Existing Service-delivery System in the Public Sector

The existing health and family-planning infrastructure in Bangladesh offers a range of health and family-planning services through a structured system, but with a vertical approach. These services are, however, not practically linked with each other, especially at the peripheral level, and therefore, are of limited use.

Tertiary level

Healthcare is available from 13 government medical college hospitals, 5 postgraduate and specialized hospitals, 1 nephrology institute, 4 tuberculosis hospitals, 5 infectious diseases hospitals, 3 leprosy hospitals, 1 mental hospital, 1 dental college hospital, 1 cancer institute and hospital, 1 child and maternal health institute, and 1 maternal and child health training institute. These institutes/hospitals provide specialized care to the people of the whole country. Besides, other ministries, e.g. railways, home, and defence, also have large hospitals primarily serving the staff of the respective ministries (3).

District level

Bangladesh has 64 administrative districts. Secondary-level healthcare is provided from 59 district hospitals. In 5 other district towns, where divisional headquarters are located, secondary healthcare is provided by the medical college hospitals. The district hospitals are 50-200-bedded hospitals with provision of wide range of modern diagnostic and treatment facilities. There are also 55 maternal and child welfare centres/maternity hospitals functioning at this level which provide maternal and child health (MCH) services, including safe-delivery practices (3).

Upazila level

The Upazila Health Complex (UHC) serves as the nucleus for the delivery of primary healthcare. The UHCs offer comprehensive health services (promotive, preventive, and curative) and, at the same time, serve as referral sources for better-equipped district hospitals. Health services at the UHC level include 31-bedded inpatient and outpatient facilities, including family-planning services, selective pathology, and limited X-ray facilities. Besides, the UHC offers domiciliary services through its multi-purpose field workers. There are 397 UHCs in the country located at all the upazilas, except the sadar upazilas of districts. In addition, 12 Maternal and Child Welfare Centres (MCWCs) located in different upazilas also provide MCH services, including safe-delivery practices, at this level (3).

Union level

To make health and family-welfare services more widely accessible to the rural people, the government has been establishing a Union Health and Family Welfare Centre (UHFWC) in each of 4,403 unions, as another fixed service-centre for the delivery of basic/primary healthcare, family planning, and MCH services. These centres do not have surgical or in-patient services; as a result, more seriously-ill patients are referred to the UHC. Recently, a provision has been created for 2 beds and other ancillary facilities for conducting normal deliveries at these centres. Besides, 23 MCWCs also provide MCH services, including safe-delivery practices, at 23 different unions (3).

Community level

Presently, the community-level health and family-planning service-delivery system (Fig. 1) is dependent on two mechanisms:

1. Home-visitation by field workers, and
2. Community-based outreach centres.

Home visitation: The grassroots-level health and family-planning workers, Health Assistants (HAs) and Family Welfare Assistants (FWAs), pay routine visits separately to the households of the same locality. While the HA visits every household of his or her service area once a month, the FWA visits once in two months. During home visits, they provide selective services scheduled to be delivered by them. Each field worker usually covers a population of about 5,000-7,000 in his/her defined area. Activities during home visits by the health and family planning workers include counselling on preventive health aspects and family-planning, collection of blood slides for malaria, distribution of vitamin A capsules, deworming tablets, family-planning commodities, and basic treatment of simple and common illnesses. There is a provision of 21,000 HAs and 23,500 FWAs. But 16,300 HAs and 19,000 FWAs are currently employed throughout the country to ensure domiciliary service-delivery. There are also 10,000 Assistant Health Inspectors (AHI) and Family Planning Inspectors (FPI) engaged in supervision of home visit-based service-delivery by the HAs and FWAs, and in organization of other community-level activities.

Outreach centres: The outreach centres in the rural community include EPI Outreach Sites and Satellite Clinics (SCs) held at a regular interval. About 120,000 outreach sites provide EPI-scheduled immunization services throughout the country with a strategy of one site per 1,000-1,200 people per month. This population-based strategy results in 24 EPI sites per month in a union. Immunization services are organized once a month at these outreach sites located at the houses or house premises of local community members. SCs are also organized once a month and at 8 sites in a union, irrespective of its population, to offer family-planning services with antenatal, postnatal and child care.

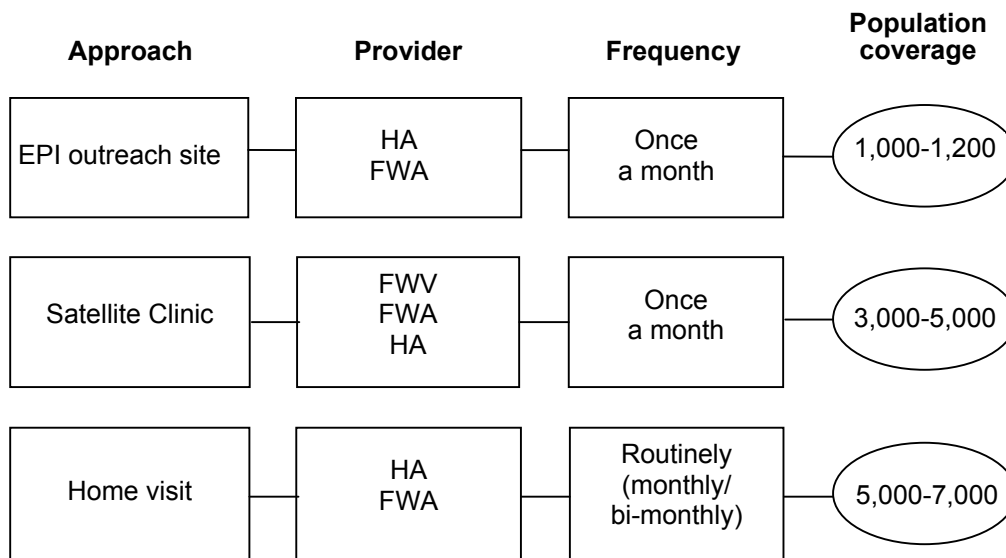

Fig. 1. Existing service-delivery system at the grassroots level

Of the total EPI sites in a union, 8 are merged with SCs to provide combined EPI, and family-planning (FP) and MCH services. The remainder EPI sites provide immunization only for the targeted population. Each SC usually covers a population of 3,000-5,000 during each session day (4). In each month, about 30,000 SCs are held throughout the country.

To provide health-related domiciliary services, there are 3-4 HAs for each union, one AHI for every 2 unions, and 2 Health Inspectors (HIs) for each upazila. On the other hand, family-planning domiciliary services are provided by 3-5 FWAs, and one FPI in each union. The Family Welfare Visitor (FWV) from the UFHWC attends the SCs on the scheduled session days. Besides, there is a provision of one Senior FWV in each upazila to oversee and support the FP-MCH activities.

The existing service-delivery system at the grassroots level is both labour-intensive and costly, and has a limited scope of services to offer at a time. The frequency of field worker's visit per household does not adequately meet the need of a family for healthcare, especially reproductive healthcare (5). Recent studies on consumer preferences and the experiences of combined EPI outreach and SCs have shown that the rural people of Bangladesh prefer one-stop provision of a package of essential services to address their basic health needs (6).

ESP Delivery in HPSP: New Service-delivery System in the Public Sector

The ESP has to be delivered in a three-tiered fixed facility-based system, with the UHC at the upazila level, the UHFWC at the union level, and the CC at the ward/village level (Fig. 2).

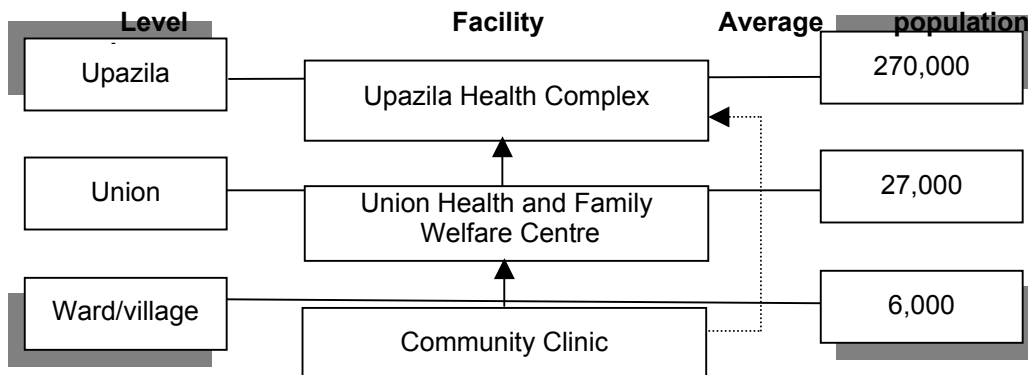

Fig. 2. ESP delivery system in rural area

The CCs will be the lowest tier of the new reorganized service-delivery system (Fig. 3). These clinics will gradually replace the existing home-based and other outreach services at the community level. The UHFWCs and UHCs will also serve the functions of a CC for the adjacent 6,000 people, while serving as the centres for referral and support for the CCs of the respective unions and upazila.

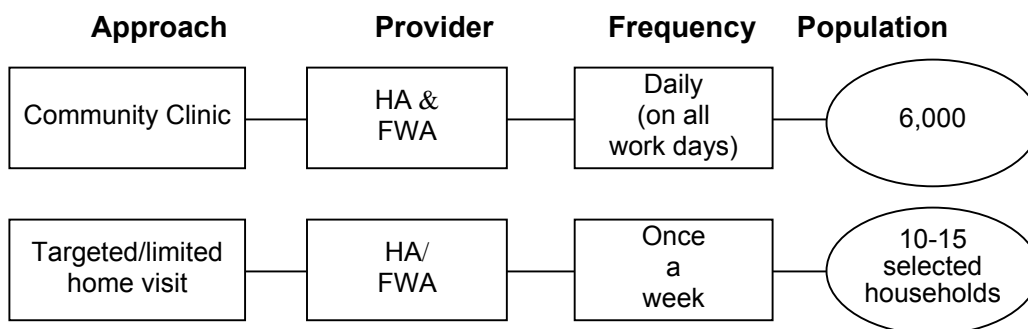

Fig. 3. Reorganized plan for service-delivery at the grassroots level

At the grassroots community level, the new service-delivery model warrants a shift in approach from the current home-visitation and makeshift outreach centres (SCs and EPI outreach sites) to the CC-based service-delivery plus limited home visits. This indicates that the existing outreach centres/SCs and the domiciliary services need to be phased out gradually. While phasing out the domiciliary services and the existing EPI outreach sites/SCs, it must be ensured that the CCs are functional and remain open daily. The HPSP envisages that, to overcome the disadvantages, including the longer travel time limiting the access/coverage especially for women and the poor, the following strategies should be undertaken:

- Scope and quality of services of CCs should be made sufficient to attract patients
- Community participation in the overall planning and setting up of the facilities (CCs) should be ensured

- Maintenance of a flexible mix of fixed-site and mobile (domiciliary and satellite type) services to facilitate the accessibility of clients who live at a great distance or whose access is limited by culture, poverty, or incapacitating medical symptoms.

Transition Plan

The HPSP has brought forward a number of new issues relating to restructuring and reorganization of the existing service-delivery strategy. It is also a shift toward meeting the needs of clients. Fig. 4 illustrates the proposed shift in the service-delivery strategy at the

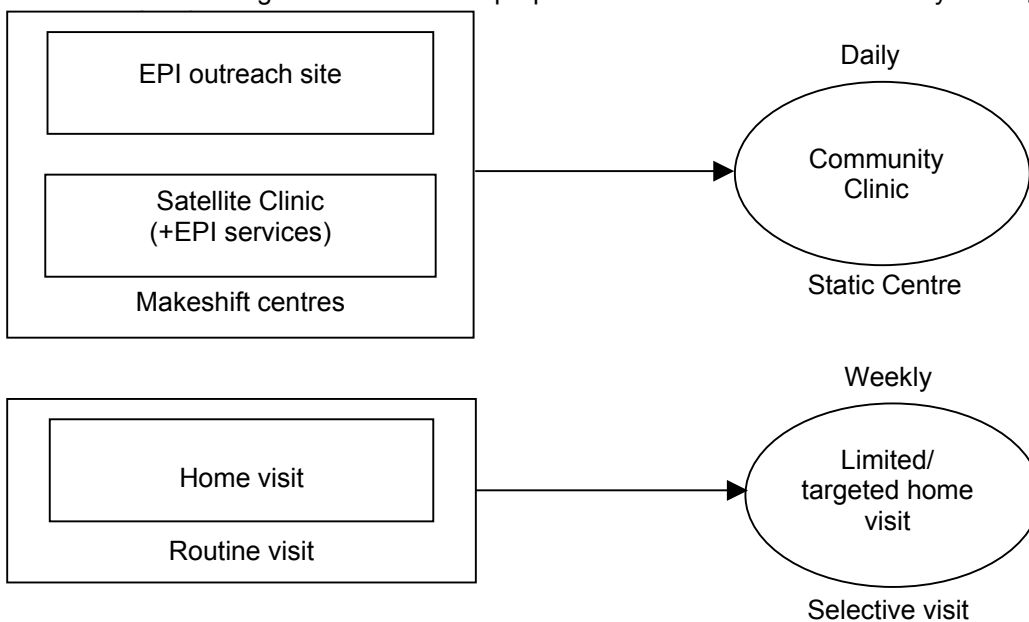

Fig. 4. Shift in service-delivery strategy

Fig. 4 shows that, in the reorganized service-delivery plan, the CCs are the only major service-delivery outlet at the grassroots level to provide basic health and family-planning services. Selective home visits to be made by the service providers, once a week, will continue to supplement the CC services as a back-up to prevent drop-out of critical service coverage. Limited home visits are also intended to provide services for the population with limited access.

With such major changes to be implemented, it is extremely critical to design how the entire programme will enter into the new stage. In other words, how the introduction of CC-based service-delivery system will replace the existing system without adversely affecting the programme coverage is a major challenge for the reform initiative. Hence, it is important to identify appropriate strategies relating to the transition from the current service-delivery system, particularly the phase-out of existing EPI outreach sites and SCs, to the delivery of ESP at the CCs.

It is commonly apprehended that the shift in the service-delivery strategy may result in an immediate fall in EPI coverage, contraceptive prevalence rate (CPR), and less use of services by children, women, and other clients (7). Therefore, while designing the plan for transition of services, the followings should be considered as conditions of the transitional operational plan:

1. The existing EPI outreach sites/satellite clinics have to be phased out gradually, so that it does not affect the use of services or service coverage negatively
2. While planning the phase out, necessary considerations should be given to the particular outreach centre for its phase-out or retainment
3. Services (domiciliary and satellite type) have to be maintained for the pocket population, i.e. clients whose access is limited by sociocultural reasons or geographical barriers
4. Limited home visits have to be continued for targeted clients, i.e. drop-outs, advanced stage of pregnancy, etc. throughout the catchment area
5. The community people must be involved in planning and managing the reorganized services, so that they can contribute to formulating an appropriate strategy
6. Information on the reorganized plan must be disseminated appropriately, so that the clients are well aware of the reorganized service-delivery points. The campaign should also target to raising clients' motivation in using services from the reorganized sites
7. A timeframe should be considered for the overall transition in phases along with the provision for needful flexibility as warranted by specific conditions.

Objectives

Although the Government of Bangladesh (GoB) guideline describes, in general term, phasing out of the existing EPI outreach sites and SCs, details of the entire process were not specified in it. As part of operations research on the delivery of ESP and CCs, it was imperative to identify appropriate strategies to address the transitional issues in relation to operationalization of CCs. To identify the appropriate transitional strategy, this study was carried out to gather perceptions of the community and the providers, and was specifically aimed at:

- i. developing strategies for:
 - phase-out of the existing EPI outreach sites and SCs
 - service-delivery for pocket population
 - targeted home visits by CC providers
- ii. identifying support activities to help implement the transition of service- delivery, including the involvement of Community Groups (CGs) and other community members, and to motivate people toward receiving services from the CCs, instead of waiting for home visits/outreach approach by the health and family-planning workers
- iii. highlighting the specific activities through which the community members can actively participate in the operation of CCs, as designated in the HPSP, and can motivate people to receive services from these clinics.

Research Questions

The following specific research questions were addressed to attain the objectives:

- i. How can the current service-delivery system based on outreach activities be gradually shifted toward the CCs without adversely affecting the use and coverage of services?
- ii. What modalities should be pursued by the CC service providers to offer services both at clinic and at doorstep of targeted clients?
- iii. How can a population with limited access be served optimally?
- iv. Which support activities are critical to help implement the transition in service-delivery?
- v. What should be the expected role of the CG in the transition process?

Materials and Methods

The study followed a qualitative approach of participatory discussions with the CG members, NGO workers-volunteers, teachers, other elected community representatives, community-level service providers, union-level supervisors, and upazila-level managers. The participatory approaches were based on the Participatory Rural Appraisal (PRA) technique. This technique enables the local people to come up with their own appraisal, analysis, action, monitoring, and evaluation regarding specific issues (A brief note on PRA can be seen in Annexure 1).

Four workshops were held with the participants of the four study unions of two upazilas, namely Mirsarai upazila in Chittagong district and Abhoynagar in Jessore district. The workshops, organized through the Upazila Health and Family Planning Manager, were conducted at the upazila during February-March 2000 (Annexure 2). A total of 123 participants attended the workshops (Table 1). Thirty-two percent of them were field-level providers and supervisors, while 40% were community members (CG members, volunteers, NGO workers, teachers, and union parishad chairman/members). Fifteen Upazila Health and Family Planning Managers (Upazila Health and Family Planning Officer, Upazila Family Planning Officer, Medical Officer-MCH, Resident Medical Officer and MOs of UHFWCs) also participated in the four workshops. Senior officials from the Directorate General of Health Services, Directorate of Family Planning, Programme Coordination Cell (PCC), and Management Change Unit (MCU) of the MOHFW also participated in the workshops. The Chief Advisor of MCU/MOHFW also attended the workshops at Mirsarai.

Table 1. Distribution of workshop participants by profession

Professional group	Mirsarai		Abhoynagar		Total (n=123)
	Dhum (n=34)	Shaherkhali (n=32)	Paira (n=30)	Baghutia (n=27)	
Provider	9	8	9	10	36
Field supervisor	3	3	3	2	11
Upazila Manager	4	4	3	4	15
UP Chairman	1	1	1	1	4
UP Member	5	4	5	5	19
Volunteer	2	2	0	0	4
CG member	2	2	2	1	7
CG President	2	2	2	2	8
Teacher	1	1	-	-	2
NGO worker	2	2		1	5
GoB official from Dhaka	3	3	5	1	12

The workshops followed the PLA technique; the participants of one union took part in the day-long discussion at each workshop. The workshops began with brief discussions on the HPSP, ESP, and CCs to reorient the participants with the new approach of service-delivery. A presentation on the existing service-delivery outlets and the proposed CC-based ESP delivery strategies was made to give a clear idea on the nature of the required transition. The presentation included maps showing the existing makeshift centres (SCs and EPI outreach sites) and the proposed CCs with the identified catchment area of the CCs. The participatory discussions, then, evolved through situation analyses of the respective unions in the context of

the present and future service-delivery systems. A set of questions (Annexure 3) was used for leading the discussion efficiently and for ensuring that all the relevant issues were addressed. In-depth discussions on each specific issue took place among the participants. The workshops, after careful analyses of the present situation and the future proposition, arrived on certain decisions and finally worked out a strategy for the transition. The workshops also deliberated on the needful supportive activities felt critical for smooth transition of the service-delivery system from the existing domiciliary and makeshift arrangements (EPI outreach centres and SCs) to the CCs. Emphasis was given on identification of the required behaviour change communication (BCC) activities and specific involvement of the community to help implement the transition plan. The participatory approach was highly useful in designing the operational guideline for the new service-delivery approach, since it provided opportunity to the grassroots-level workers and community members to share their views and ideas on developing the service-delivery plan of their own community. The workshops offered a forum for the providers and the community members to exchange their views, share experiences, and reach consensus on the reorganized service-delivery strategy for the locality.

Results and Discussion

Phase-out of Outreach Centres

The discussions in the workshop led to the development of some principles to identify the specific time of transition and the specific sites to be phased out gradually. The decisions were based on some assumptions or considerations (Table 2). A CC is planned for an average of 6,000 people, and this population lives in an area defined as the catchment of a CC. The existing makeshift service-delivery centres are spread around in the defined catchment area of the CC. This consideration was in the centre of the phase-out plan. It was also assumed that most of the catchment population (more than 80%) would be able to access the CC by 30-minute walking which means about one and half km walking for a woman. The assumptions were adopted as the basis of the phase-out plan (Table 2).

Table 2. Phase-out plan of the existing outreach centres

Decision	Assumptions/considerations
EPI outreach sites/SCs, located within 10-15 minute walking distance from the CC, would be withdrawn during the first phase (as soon as the CC starts functioning)	<ul style="list-style-type: none"> ▪ A woman usually covers half to 3-quarter km distance by 10-15-minute walking, which is not so long to deter accessibility ▪ Most community members at present walk 10-15 minutes to use services from outreach sites or SCs ▪ The rural people may not be unwilling to walk for 10-15-minutes or even more ▪ Intensive BCC activities will be undertaken to provide messages on phase-out to the community members who use the services. The BCC campaign would be launched as soon as the construction work begins
EPI outreach sites and SCs, located further away i.e. beyond 10 to 15-minute walking distance, from the CC, would be continued for 3-6 months from the date of opening of the CC	<ul style="list-style-type: none"> ▪ Closure of the outreach centres from the distant population before making them aware of the new strategy may affect the use and coverage of services ▪ A minimum of three months may be allowed to conduct BCC campaign to make people aware of the phase-out issue ▪ Too a long transition period may not be helpful for behaviour change of clients toward using services from CC

Table 2. *contd...*

Table 2. (contd.)

Decision	Assumptions/considerations
<p>A 3-6-month transition period for phasing out of distant EPI outreach sites/SCs is required to maintain the service coverage and to motivate the local community about the benefits of the new service-delivery system</p>	<ul style="list-style-type: none"> ▪ People living at a distance of more than 10-15 minutes of walking may be reluctant to visit CCs for regular services at the initial stage ▪ A considerable time (minimum 3 months) is required to make people aware of using the services from the CC ▪ People living at a distance need some time to be familiar with the location of the new clinic ▪ The field workers will get some more time for communicating messages on phase-out to the community ▪ Instant closure of the distant sites may lead to the danger of leaving the target communities and make them feel unserved
<p>The centres that would persist for a transition period of 3-6 months should be conducted as a merged site for EPI and SC services</p>	<ul style="list-style-type: none"> ▪ More services should be available at the merged outreach sites during the transition period
<p>A workplan would be made for the transition period to operate the CC and the remaining outreach centres/SCs of the catchment</p>	<ul style="list-style-type: none"> ▪ EPI and SC services would be merged ▪ Merged sites will be attended by the FWV and HA for providing immunization, while the FWA would remain in the CC ▪ EPI services would be given at the CC either once or twice a week ▪ The CC will be kept open for all working days. One of the two workers will remain at the CC, while the other will make selected home visits at the community one day a week, or if necessary, in an increased frequency

The workshop discussions directed the participants to formulate a two-phase planning strategy for the phase-out of the existing outreach centres. Based on the above strategy, the workshop participants identified the specific sites to be phased out in the first phase, i.e. at the beginning of functions of the CC (Annexure 4). Table 3 illustrates the number of sites to be phased out at the initial stage and the number of sites to be continued for 3-6 months of operation of CCs.

Table 3. Distribution of EPI outreach sites/satellite clinics for phase-out in phases

Upazila	Union	Total no. of existing EPI/SC sites	Sites to be phased out in phase 1		Sites to be continued in phase 2	
			No.	%	No.	%
Abhoynagar	Paira	24	11	46	13	54
	Baghutia	24	11	46	13	54
Mirsarai	Shaherkhali	24	17	71	7	29
	Dhum	24	16	67	8	33
Total	4 Unions	96	55	57	41	43

The findings of the workshops indicate that 55 (57%) of the existing 96 EPI outreach sites/SCs may be phased out as soon as the CCs start operation, while the rest 41 (43%) should be continued for another 3-6 months and then be phased out completely. The participants agreed that such phasing out will not affect immunization rate, coverage of antenatal and postnatal care, CPR, etc. The proposed numbers of phased out sites are, however, dependent on the synchronization of support activities, i.e. BCC campaign, activities performed by the CG members, etc., with the simultaneous operation of CCs in a union. The Upazila Managers also were in consensus with the opinion that, with effective motivation of clients, the gradual phase-out plan would have no negative impact on the use of services and the performance of indicators. However, some participants expressed cautions about the negative effect in service use, and therefore, a decision was made to closely monitor the effects of phase-out, and respond immediately to overcome the adverse effects, if any.

The workshops with all the 4 union participants reached a consensus that a workplan is needed for the transition period to operate the CCs and the remaining EPI outreach centres/SCs within the catchment of a CC. The basic principle of the workplan for each union would be as follows:

- EPI outreach centres and SCs will be merged
- EPI services will be given at CCs once or twice a week
- During the 3-6 month transition period, EPI centres/SCs, located outside the CCs, will be attended by HA; the FWV will join him/her at the site
- CCs will be kept open on all working days
- Selected home visits will be made once a week by both HA and FWA, but not simultaneously. While one of them will be on home visit, the other provider will remain at the CC.

The work plans of HA, FWA, and FWV may be displayed at CCs. All the service providers will receive uniform training on ESP to offer services, and the training is expected to be completed before formal opening of CCs.

Workshop at Mirsarai

The group exercise demonstrated that 71% and 67% of the existing outreach sites may be phased-out, respectively, at Shaherkhali and Dhum unions of Mirsarai (Table 3). Annexure 4 shows the specific sites to be phased out in Phase 1. The participants from Mirsarai emphasized that even the female clients would be able to reach CC located within the 10-15 minute walking distance from these outreach centres. The participants of Shaherkhali opined for a 3-6 month long second phase, and the representatives of Dhum union expressed that,

right at the moment, it might not be possible to fix up any time limit for the remaining sites to be phased out. It depends on how smoothly the CCs can operate. The participants, although few in number, expressed that, immediately after the opening of CCs, all the outreach sites could be phased out simultaneously. At the same time, intensive mass campaign should be undertaken to make the community aware of the change of the service-delivery points.

Workshop at Abhoynagar

It was revealed that 46% of the existing outreach sites might be phased out at both Paira and Baghutia unions of Abhoynagar. Annexure 4 shows the specific sites to be phased-out in Phase 1. The participants opined that the EPI sites/SCs, located further away (beyond 15-minute walking distance) from the CCs, would be continued for a further period of 3-6 months. They were more conservative in making the total phase-out plan. However, arguments were raised in favour of phasing out of all the EPI sites/SCs simultaneously with extensive BCC campaign. They identified two SCs, which currently serve an ethnically-segregated population. The participants opined that these two centres would be continued for a longer period as special arrangement for the catchment pocket population.

Support Activities

Discussions in the workshops further revealed that effective implementation of phase-out of the existing service-delivery sites depends on certain support activities. Table 4 describes the support activities to be carried out at the CC catchment area to help the effective implementation of the phase-out plan. Table 4 also identifies the methods of disseminating messages on the phase-out plan as expressed by the discussants. In the workshops, BCC activities were identified as the most important support activities and interpersonal communication was identified as the major means of message dissemination. While the health and family-planning field workers would initiate message dissemination on the phase-out plan, it was suggested to be reinforced and confirmed by the CG and other community members. Such reinforcement would likely to convince the community members to receive services from the new service-delivery points, instead of the old ones, as instructed in the messages. Several activities were proposed to be performed by the community members who volunteered to shoulder the desired responsibilities to support the service providers in implementing the phase-out plan. Those community members who volunteered to participate in the plan included the CG members, Union Parishad chairmen/ members, school teachers, religious leaders, social workers, and members of women's forum and youth clubs. Some activities may require financial support from the local Union Parishad and/or the community members.

Table 4. Support activities for the phase-out plan

Support activity	Media	Responsibility
Messages will be delivered from 2 months prior to inauguration of CC	Interpersonal communication and leaflets	Field workers, CG members, and UP chairmen/members
HA and FWA will provide these messages during their home visits and during the sessions held at the existing makeshift centres	Interpersonal communication, leaflets, and posters	Field workers and field supervisors
Community members will also inform the community people about this arrangement	Interpersonal communication and miking from mosques	CG members, school teachers, women's group members and religious leaders
HA, FWA, and FWV will provide BCC message during SC/EPI sessions	Interpersonal communication, leaflets, and posters	HA/FWA and FWV
Community members will also provide messages on the phase-out plan	Interpersonal communication	Members of CG and youth club
Health workers will talk to people to convey the message to 10 other people	Interpersonal communication	HA, FWA, AHI and FPI, and other social workers
FPI, AHI, and FWV will also provide messages on the phase-out plan	Interpersonal communication and leaflet	FPI, AHI, FWV, and other women volunteers

Targeted Home Visits

Although the CC-based service-delivery system will eventually replace the existing makeshift service centres and domiciliary visits, a provision for targeted and limited home visits has been made in the government guideline as a back-up arrangement during the transition period. This arrangement is likely to be continued beyond the transition period to avert any potential adverse situation. It is apprehended that a complete withdrawal of the existing system may result in a drop of service use, thereby reducing the coverage. This concern can not be ruled out totally in the context of many sociocultural taboos prevailing in rural Bangladesh. However, the social values in the rural communities are changing fast, and studies have demonstrated that the use of services did not fall when the clients, particularly women, were asked to receive services from a particular service-delivery outlet. The positive experience of EPI outreach sites and SCs also supports this notion. Nevertheless, it is important to establish the CC-based service-delivery system and to observe the effects for some time before a final decision is made. The service providers would continue to make selective or targeted home visits to prevent the drop of coverage of critical services e.g., EPI, FP, and to provide some selective services to the local populace. The new Unified Management Information System (UMIS) has developed a framework for limited home visits. For example, critical service needs of clients are recorded in a Follow-up Register maintained at CCs. This register helps the providers to identify the drop-outs of services and, thus, guide limited home visits for follow-up of those cases.

From the participatory learning approach of the workshops, the following issues were elicited as means to carry out the targeted home visits during the transition period:

- Selected home visits should be conducted by both HA and FWA, based on the Follow-up Register provided in the UMIS. The Follow-up Register has a provision to monitor the drop-out cases who are supposed to visit the CC regularly and are recorded in the register accordingly. However, they will visit the targeted clients on separate days, so that the clinic can remain open.
- The field supervisors can contribute to the limited home-visitation programme as it is included in their new job description. They can collect information about targeted clients (drop-outs of family-planning methods, tuberculosis drugs, and handicapped and clients unwilling to attend CCs) from the households and inform the HA and FWA. The HA and FWA can visit those selected households accordingly.
- Drop-out cases can also be identified from the clinic register. This register can also be a good source to identify the target population.
- Some financial/logistic support may be extended to the HA/FWA either by the CG or by the Union Parishad for transportation during targeted home visits.

Service-delivery for Pocket Population

The population of Bangladesh is almost homogeneous in cultural aspects and also in geographical distribution in most parts of the country. However, there may still be some sub-groups of population who have limited access to the healthcare- delivery systems. Access of such population may either be limited because of their different sociocultural belongingness or because they are segregated from the main population cluster by a natural barrier, such as water bodies, hills, etc. This sub-population often does not receive services from the existing health systems, and special arrangements need to be made to provide services to them. This group of population may be identified as pocket population, and special provision of service-delivery should be maintained for them. However, continuous efforts should be made to motivate them to use services from the CCs. The availability of wide range of services at the CCs may eventually attract them toward the CCs. The workshop participants suggested making the following arrangements for ensuring service-delivery to the pocket population.

- A mix of mobile and fixed-site (SC+EPI) services may be maintained for this population until they are motivated enough to use services from the regular centres.
- Needs assessment of such population should be carried out, and services could be designed for them accordingly.
- There are excess staff in some areas; these staff can be engaged for delivering services to the pocket population.

The concept of pocket population is especially applicable for Chittagong and Sylhet regions. However, there may also be a few sociocultural subgroups, such as ethnic groups, with less access to health services in other areas as well. Population with geographic inaccessibility may also prevail in other parts of the country.

Lessons Learned

The proposed transition plan was put into operation in some unions of the study area to examine their effects. The lessons learned in the formulation of the transition plan in the study unions are as follows:

1. The plan for reorganization of the service-delivery outlets at the grassroots level should be done at the local level with one CC catchment area taken as the unit for planning transition of services.
2. It may not be necessary to consider all the CCs and their catchment population within the union simultaneously, while planning the phase-out of existing makeshift centres, e.g. EPI outreach sites and SCs.

3. The number of existing sites to be phased out in the first phase may vary from union to union depending on their geographical size, the clustering pattern of dwelling of inhabitants, and accessibility.
4. Sociocultural and geographical factors that may impede service use and service-delivery must be carefully analyzed for identifying the sites to be phased out gradually or retained as considered necessary for the needs of pocket population.
5. The planning exercise should be conducted in a participatory way ensuring active involvement of the community members and service providers. Holding of a day-long workshop for each union may ensure participation of relevant stakeholders from the union.

Recommendations

Transition of services from the existing system to the CC-based system should be planned at the local level. The Upazila Health and Family Planning Managers, in consultation with the field-level providers, supervisors and the community representatives may prepare a plan for each union. During the preparation of the plan, the local factors should get sufficient consideration. Although the transition plan will be a local effort, an operational guideline would help the local staff and community to adapt it according to the local needs. Analyses of the existing situation on the service-delivery and issues relating to use of the services by the rural communities suggest that the following points be considered while developing a strategy for the transition plan:

1. A three-phase strategy may be adopted to phase-out the existing EPI outreach sites and SCs and to initiate one-stop provision of ESP from CCs.
2. Phase 1 may be considered the preparatory phase for promoting the CCs as an ESP delivery centres of the catchment populations and disseminating messages on phase-out of the existing outreach sites. Phase 2 and 3 may be the periods when the existing outreach sites can actually be phased-out gradually.
3. The existing outreach centres, such as EPI sites and SCs, located within 15-minute walking distance of a CC, may be phased-out in the second phase, i.e. as soon as the CC starts functioning.
4. To ensure the continuity of vaccination dates of individual clients, the vaccination sessions scheduled for clients of the withdrawn sites may be temporarily held at the CC on the same days of the month as scheduled previously (for the withdrawn outreach centres).
5. The outreach centres, located farther away (beyond 15-minute walking distance) from CCs, should be continued for a period of 3-6 months from the date of opening of CCs to support the prevailing coverage, make aware, and motivate the local communities on the use of the new service-delivery arrangement.
6. Total phase-out of all the existing outreach sites, except the ones meant for or located in a pocket population, i.e. population with limited access, should be completed after 6 months from the beginning of operation of CCs with extensive BCC support. However, the managers, supervisors, and providers should maintain close links with the local community, and monitor the trends of service use.
7. After the total phase-out of outreach sites, the vaccination sessions may be organized once a week in a CC and once a month in a retained site for the pocket population, as necessary.

8. The outreach sites to be retained either for 3-6 months or for an indefinite period for a pocket population should be operated as merged sites.
9. Both makeshift outreach centres, e.g. SC and EPI outreach site, and domiciliary services should be continued for the pocket population until they are sufficiently motivated to use the services from CCs. The excess field staff, if any, may be assigned for this purpose.
10. Local elites of the rural community, e.g. UP Chairmen and members, school teachers, NGO workers, small business entrepreneurs, imams of mosques, other religious people, service-holders, and, of course, the CG members, should be involved to motivate the local people to use one-stop provision of the integrated services within the new service-delivery systems.
11. The people involved in cooperatives, such as mothers' club, youth club, bazar committee, and also village police (Village Defense Party), can motivate the rural people about the transition plan, i.e. the shift in service-delivery strategy, and request them to seek care from the CCs.
12. The health and family-planning workers, during their routine doorstep visits, should inform the village mass about the CCs and the phase-out plan. They can start informing the community as soon as the construction of a CC begins.
13. The Follow-up Register introduced under the UMIS may be used as the basis for selective home visitation. The drop-out clients listed in that register should only be targeted during limited home visit by CC providers. The Geographical Reconnaissance (GR) data for the CC catchment population may be a source to identify the drop-outs of vaccination, antenatal care, contraceptive acceptance by ELCOs and DOTS for tuberculosis. However, the field supervisors should continue their vigilance to see if there are other clients who need a home visit.

Box 1 describes the activities to be performed (Plan A) at the implementation level to execute the transition plan based on the above recommendations. A critical path analysis for the important activities to be conducted for full functioning of CC with the implementation of the transition plan is given in Chart A in Annexure 5. The activities depict sequential chronology as to how they should be accomplished. The bolded activities denote the most critical ones, to be completed for appropriate and timely implementation of the CC-based service-delivery system. The Upazila Managers should identify the specific block where the respective CCs are operating. While doing so, they should look back, and accomplish all the unfinished tasks before proceeding further in the path of transition toward establishing a full-fledged CC-based service-delivery system.

Box 1. Transition plan on shift from outreach to CC-based service-delivery system

Plan A

(For places where service-delivery at CC is not initiated)

Phase 1. Preparation for transition (duration: 2 months)

1. The CC should be promoted as the ESP delivery centre of the catchment population (or villages), as planned during site selection.
2. Day-long planning workshops should be conducted at the upazila level to develop a plan for phasing out of the existing outreach sites within the CC catchment area. These workshops--one for each union--should be held with the providers and local community members (see the list of participants).
3. Service-delivery from the CC must be initiated within two months of the planning workshop.
4. Messages on phase-out of the existing outreach sites must be disseminated from two months prior to initiation of service-delivery from the CC.
5. At the union level, the planning workshop must be followed by the activities noted below:
 - a. The HA/FWA should convey messages on phase-out of the specific outreach sites during their home visits.
 - b. The HA/FWA and the FWV should deliver messages on the phase-out schedule during the respective SC/EPI outreach sessions.
 - c. The CG members should visit the primary schools and request the students to motivate their household members and neighbours to use the CC for health and related services.
 - d. The FPI/AHI/FWV should talk to the local people, primary school teachers/and religious leaders, and provide messages on the phase-out plan to the respective communities during their supervisory visits.
 - e. The UHFPO should arrange a meeting with the Chairman and members of the Union Parishad and brief them about the plan.
 - f. The CG members should also disseminate messages on the phase-out arrangement of the outreach sites, and encourage people at their localities to receive required services from the CC.
6. The CG members and other community members should be assigned with the responsibilities to follow-up the vaccination dates with mothers, as mentioned in the EPI Cards and/or the Family Health Cards, and motivate them to take their children to the CC for immunization and other essential child health services. Efforts should also be made to identify and orient volunteers to help them in these activities.

Box 1. *contd..*

Box 1. (contd.)

7. All tasks described in the Chart titled "Critical activities for implementation of transitional plan (Plan A) on shift from outreach to CC-based Service-Delivery System" should be duly accomplished to proceed with the transition.

Phase 2. Partial phase-out (duration: 3-6 months)

1. The outreach centres (EPI sites and SCs), located within 15-minute walking distance of a CC, should be phased-out as soon as the CC starts functioning.
2. The remaining outreach sites within the CC catchment area should be continued as usual, and should be operated as merged (SC+EPI) sites until these are fully phased out within next 3-6 months.
3. To maintain the correct schedule of the vaccination dates, the EPI sessions scheduled for the communities of the withdrawn centres will be held temporarily at the CC on the same days of the month as scheduled previously (for the withdrawn outreach centres). The vaccines should be supplied to the respective CC on the specified days. Arrangements should also be made to return the vaccine carriers and unused vaccines to the UHC accordingly.
4. The FWV should visit the CC twice a month on specific days, and continue visiting the remaining merged outreach sites as scheduled previously. Dates of the FWV's visits to the CC and to the remaining outreach sites should be planned in such a way that they do not conflict with each other.
5. The health and family-planning workers and the CG members should continue to deliver messages on total phase-out of the outreach sites, and motivate the respective communities to receive services from the CC, including child immunization, maternal health, and family-planning services. The health and family-planning workers should deliver these messages while providing services at the CCs and merged outreach sites, as well as during limited follow-up home visits.
6. The transition to the CC-based service-delivery should be monitored very closely. The following activities should be conducted to monitor the transition plan:
 - a. The EPI and family-planning performances should be reviewed carefully with particular attention to the reports for the sites phased out initially.
 - b. Use of the CCs should be monitored routinely by reviewing UMIS and/or other reports from CCs.
 - c. The AHI/FPI should visit and collect information on the use of CC services from the phased-out communities.
 - d. The status should be reviewed regularly in coordination meetings at all levels.
7. The CG should be activated to work on the phase-out plan.

Box 1. contd

Box 1. (contd.)

Phase 3. Complete phase-out

1. The remaining outreach centres, located further away (beyond 15-minute walking distance), have to be phased-out in this phase, except the ones catering to the needs of pocket population.
2. The centres retained in the pocket population should be operated as merged sites where the EPI and SC services should be provided as before.
3. The EPI sessions, from this phase onwards, should be held once a week on specific days at the CC. However, the vaccination sessions may be organized once a month at the retained sites for the pocket population, if any.
4. The FWV should continue visiting the CC twice a month and visit the merged outreach sites retained for the pocket population, if any, once a month.
5. The health and family-planning workers (CC providers) and supervisors should undertake follow-up visits to monitor drop-outs of services. Active linkages should be maintained with the catchment population to motivate them in using the CCs.
6. EPI performance and use of contraceptives should be reviewed periodically to monitor the coverage.
7. Necessary actions (e.g. intensive BCC activity, inter-personal contact with the community people, encouraging transportation support from the community, etc.) must be taken immediately, if any adverse effect of the shift on the above two key indicators is observed anywhere. Efforts to remove barriers to the CC-based service provision, if any, may also be pursued through the local government or through the relevant local authorities of other ministries.

Potential participants for the transition plan workshop

The following groups of people should be invited to join the transition plan workshops, but the number of participants should be limited to 30-35 for each union:

- CC providers--HA and FWA
- Field Supervisors--AHI, FPI, HI, SI, Senior FWV, and ATFPO
- EPI Technician of UHC
- Upazila Managers--UHFPO, RMO, UFPO, MO (MCH-FP)
- UP Chairman and Members (Women)
- CG President
- CG Members (Women)
- Cooperative Society Chairman and member
- School teacher
- Women and youth organizers
- NGO worker
- Religious leader

It is understandable that as the CCs are being established in phases throughout the country for about a year or more, some CCs have already initiated steps to deliver services. In places where the CCs have already started functioning, the managers may find some difficulty in following the sequence of activities described and demonstrated in Box 1 (Plan A) and Chart A. Hence, an alternate plan (Plan B) is presented in Box 2 and Chart B (Annexure 6), which allows the managers of the places where the CCs have already started functioning to adapt the plan according to their local conditions, i.e., progress of establishment and operationalization of

CCs. However, Plan A should obviously be followed in places where service-delivery is yet to be initiated.

Box 2. Transition plan on shift from outreach to CC-based service-delivery system

Plan B

(For places where service-delivery at CC has been initiated)

Phase 1. Preparation for transition (duration: 2 months)

1. The CC should be promoted as the ESP delivery centre of the catchment population (or villages), as planned during site selection.
2. Day-long planning workshops should be conducted at the upazila level to develop a plan for phasing out of the existing outreach sites within the CC catchment area. These workshops--one for each union--should be held with the service providers and local community members (see list of participants).
3. Messages on phase-out of the existing outreach sites must be disseminated for at least two months prior to initiation of their phase-out.
4. At the union level, the planning workshop must be followed by the activities noted below:
 - a. The HA/FWA should convey messages on phase-out of the specific outreach sites during their home visits.
 - b. The HA/FWA and FWV should deliver messages on the phase-out schedule during the respective SC/EPI outreach sessions.
 - c. The CG members should visit the primary schools and request students to motivate their household members and neighbours to use the CC for health and related services.
 - d. The FPI/AHI/FWV should talk to the local people, primary school teachers, and religious leaders, and convey messages on the phase-out plan to the respective communities during their supervisory visits.
 - e. The UHFPO should arrange a meeting with the Chairman and members of the Union Parishad and brief them about the plan.
 - f. The CG members should also disseminate messages on the phase-out arrangement of the outreach sites, and encourage people at their localities to receive required services from the CCs.

Box 2. *contd...*

Box 2. (contd.)

9. The CG members and other community members should be assigned with the responsibilities to follow-up the vaccination dates with mothers, as mentioned in the EPI Cards and/or the Family Health Cards, and motivate them to take their children to the CC for immunization and other essential child health services. Efforts should also be made to identify and develop volunteers to help them in these activities.
10. All tasks described in the Chart titled "Critical activities for implementation of transition plan (Plan B) on shift from outreach to CC-based service-delivery system" should be duly accomplished to proceed with the transition.

Phase 2. Partial phase-out (duration: 3-6 months)

1. The outreach centres (EPI sites and SCs), located within 15-minute walking distance of a CC should be phased out after the preparatory activities are accomplished.
2. The remaining outreach sites within the CC catchment area should be continued as usual, and should be operated as merged (SC+EPI) sites until these are fully phased out within next 3-6 months.
3. To maintain the correct schedule of the vaccination dates, the EPI sessions scheduled for the communities of the withdrawn centres will be held temporarily at the CC on the same days of the month as scheduled previously (for the withdrawn outreach centres). The vaccines should be supplied to the respective CC on the specified days. Arrangements should also be made to return the vaccine carriers and unused vaccines to the UHC accordingly.
4. The FWV should visit the CC twice a month on specific days, and continue visiting the remaining merged outreach sites as scheduled previously. The dates of FWV's visits to the CC and the remaining outreach sites should be planned in such a way that they do not conflict with each other.
5. The health and family-planning workers and the CG members should continue to deliver messages on total phase-out of the outreach sites, and motivate the respective communities to receive services from the CC, including child immunization, maternal health, and family-planning services. The health and family-planning workers should deliver these messages while providing services at the CCs and merged outreach sites, as well as during limited follow-up home visits.
6. The transition to the CC-based service-delivery should be monitored very closely. The following activities should be conducted to monitor the transition plan:
 - a. The EPI and family-planning performances should be reviewed carefully with particular attention to the reports for the sites phased-out initially.
 - b. Use of the CCs should be monitored routinely by reviewing UMIS and/or other reports from CCs.
 - c. The AHI/FPI should visit and collect information on the use of CC from the phased-out communities.
 - d. The status should be reviewed regularly in coordination meetings at all levels.
7. The CG should be activated to work on the phase-out plan.

Box 2. contd...

Box 2. (contd.)

Phase 3. Complete phase-out

1. The remaining outreach centres, located further away (beyond 15-minute walking distance), have to be withdrawn in this phase, except the ones catering to the needs of pocket population.
2. The centres retained in the pocket population should be operated as merged sites where the EPI and the SC services should be provided as before.
3. The EPI sessions, from this phase onwards, should be held once a week on specific days at the CC. However, the vaccination sessions may be organized once a month at the retained sites for the pocket population, if any.
4. The FWV should continue visiting the CC twice a month and visit the merged outreach sites retained for the pocket population, if any, once a month.
5. Follow-up visits should be planned and undertaken by the health and family-planning workers (CC providers) and supervisors to monitor drop-outs of services. Active linkages should be maintained with the catchment population to motivate them in using the CCs.
6. EPI performance and use of contraceptives should be reviewed periodically to monitor the coverage.
7. Necessary (e.g. intensive BCC activity, inter-personal contact with the community people, encouraging transportation support from the community, etc.) actions must be taken immediately, if any adverse effect of the shift on the above two key indicators is observed anywhere. Efforts to remove barriers to the CC-based service provision, if any, may also be pursued either through the local government or through the relevant local authorities of other ministries.

Potential participants for the transition plan workshop

The following groups of people should be invited to join the transition plan workshops, but the number of participants should be limited to 30-35 for each union:

- CC providers--HA and FWA
- Field supervisors--AHI, FPI, HI, SI, Senior FWV, and ATFPO
- EPI Technician of UHC
- Upazila Managers--UHFPO, RMO, UFPO, and MO (MCH-FP)
- UP Chairman and Members (Women)
- CG President
- CG Members (Women)
- Cooperative Society Chairman and member
- School teacher
- Women and youth organizers
- NGO worker
- Religious leader

Conclusion

Revisiting of a strategy is often made to increase efficiency. Reorganization and restructuring of service-delivery in the HPSP have to be implemented gradually to minimize the risks involved in the process. At the implementation level, the common concern is to support and maintain the performance level attained so far, and take necessary steps to introduce the new service-delivery strategies. It is, thus, important that the new service-delivery plan optimally addresses the relevant concerns with appropriate considerations.

The participatory learning approach, used for developing the transition plan, allowed the study team to use the experience of the field workers, supervisors, programme managers, and community members, and to depend on their best guess about the possible effects of the plan. It also helped identify the most rational opinions of the attending stakeholders, and make them feel involved and committed to the planning process. The workshops provided useful inputs to chalk-out a transition plan, together with relevant stakeholders of health and family-planning services at the grassroots level. This plan, however, is based on the optimum judgments of the concerned participants, and may deem to be enthusiastic to some extent, particularly in respect to the support activities to be performed by the community members. One should not forget that much of its success lies on the active participation of the community. Persistent efforts should, thus, be continued by the authorities concerned to involve them in implementing the plan. It is also very important that the execution of the plan and its effects are observed closely. Continued operations research should be conducted to monitor and evaluate its effectiveness. There should be enough flexibility in the transition-implementation process to accommodate corrective measures.

References

1. Bangladesh. Ministry of Health and Family Welfare. Health and Population Sector Programme (HPSP) 1998-2003: Project Implementation Plan, Part I. Dhaka: Ministry of Health and Family Welfare, Government of Bangladesh, 1998:19-20.
2. Bangladesh. Ministry of Health and Family Welfare. Guidelines on establishment of community clinic. Dhaka: Ministry of Health and Family Welfare, Government of Bangladesh, 1999:1-6.
3. Bangladesh. Directorate General of Health Services. Bangladesh health bulletin 1996. Dhaka: Directorate General of Health Services, Ministry of Health and Family Welfare, Government of Bangladesh, 1998:20-28.
4. Hasan Y, Barkat-e-Khuda, Ashraf A, Kane TT, Ahmed MU, Reza MM. Essential service package: key findings from an operations research in rural Bangladesh. Dhaka: International Centre for Diarrhoeal Disease Research, Bangladesh, 1997. (Unpublished working paper).
5. Routh S, Arifeen SE, Jahan SA, Begum A, Thwin AA, Baqui AA. Developing alternative service delivery strategies for MCH-FP services in urban areas: findings from an experiment. Dhaka: International Centre for Diarrhoeal Disease Research, Bangladesh, 1997. (ICDDR,B working paper, 106).
6. Hasan Y, Barkat-e-Khuda, Levin A. Strengthening outreach sites through an approach combining satellite clinics with EPI. Dhaka: International Centre for Diarrhoeal Disease Research, Bangladesh, 1997. (ICDDR,B working paper, 87).
7. Ashraf A, Barkat-e-Khuda, Rahman M, Reza M. The delivery of maternal and child health and family planning services through cluster visitation. Dhaka: International Centre for Diarrhoeal Disease Research, Bangladesh, 1997. (ICDDR,B working paper, 89).

Participatory Rural Appraisal

Participatory Rural Appraisal (PRA) is the label which has been attached to a growing family of relaxed approaches and methods to enable local people to make their own appraisal, analysis, and plans, share information, act and monitor, and evaluate actions and programme.

PRA has evolved from many sources, including participatory action research, applied social anthropology, agro-ecosystem analysis, field research on farming systems, and rapid rural appraisal (RRA). RRA was developed and spread in the late 1970s and 1980s as a reaction against the biases of rural development tourism (the brief rural visit of the urban-based professional) and the distortions, costs, and inefficiencies of questionnaire surveys.

RRA and PRA share the principles of learning from and with people, directly, on site and face to face, learning rapidly and progressively, offsetting biases, optimizing trade-offs between quantity, relevance, accuracy and timeliness of information, triangulating (cross-checking) and seeking diversity.

The purpose of RRA is learning by outsiders. Many practitioners insist that PRA is different. Its aim is to facilitate appraisal and analysis by local people themselves. We, outsiders, enable them to do many things we thought only we could do.

PRA has three pillars--methods, behaviour and attitudes, and sharing. Of these, behaviour and attitudes are the most important. PRA stresses: unlearning; self-critical awareness and responsibility, embracing error, 'handing over the stick', having confidence that they can do it; being nice to people, sitting down, listening, learning and not interrupting; patience and not rushing; and using one's own best judgment at all times.

PRA derives much of its strength from emphasizing: open-ended enquiry, visualization (maps, matrices, diagrams, models), comparisons, and analysis by groups. PRA methods, such as semi-structured interviewing, are also used for PRA. In addition, much PRA facilitates the use of relatively new methods, in a participatory way, such as participatory mapping and modelling, transact walks and observation, seasonal calendars, timelines and trend, matrix scoring and ranking, wealth and well-being ranking and grouping, institutional diagramming, and analytical diagramming.

Annexure 2

**Schedule of Workshop on Development of
Transition Plan for Community Clinics**

Upazila	Union	Workshop date	No. of participants (n=123)
Abhoynagar	Paira	19 February 2000	30
	Baghutia	20 February 2000	27
Mirsarai	Shaherkhali	11 March 2000	32
	Dhum	12 March 2000	34

**Questions for Discussion on
Development of Transition Plan on Shift from the Existing System to the
Community Clinic-based Service-delivery System**

1. Can all the centres stop functioning together right after operationalization of Community Clinics?
2. Why cannot all the centres stop functioning together?
3. How can we identify the outlets/sites that can be phased out immediately?
4. Can you locate all the centres that will phase out at first stage?
5. How can we chalk out the phase-out plan for other EPI outreach centres/SCs?
6. Can you locate the outlets that require an additional time to phase out?
7. What would be the feasible time period for these service-delivery sites to phase out?
8. How many EPI centres/SCs under one CC should keep on operating during the take-off period?
9. Can you develop a workplan for the providers during the take-off period to operate CC and its remaining EPI outreach/SCs?
10. What can be the service-delivery system for pocket population?
11. How can you identify these pockets?
12. Why do you think these pockets should receive attention?
13. What can be the support activities (BCC) to implement the phase-out plan?
14. Who are the people suitable to be involved in the support activities?
15. How can the CGs and other community members contribute to such activities?
16. When BCC campaign will start?
17. For how long the campaign will go on?
18. How the limited households can be identified for home visits?
19. What can be the home-visitation plan for the identified households?
20. How can the absentee cases be identified?
21. Can there be any alternative arrangement for the absentee cases?
22. How can CG or other community members motivate the drop-outs to visit CC?

Annexure 4

**Worksheet for Planning
Phase-out of Satellite Clinics and EPI Outreach Sites within
the Community Clinic Catchment Area**

Union: **Saherkhali**

Thana: **Mirsarai**

District: **Chittagong**

Community Clinic	EPI sites in the catchment area (in the house of)	Satellite Clinics (+EPI services) in the catchment area (in the house of)	To be continued for		Special arrangement/ remarks	
			0 month	3-6 months		
Doom Khali	Goldar		✓			
	Ramkrishna Mohan			✓		
	Mahatab Chowdhury		✓			
	Gazaria Primary School		✓			
	Abu Noor		✓			
		Kalam Master	✓			
		Md. Nazir	✓			
	Forest Office			✓		
Dakshin Mogadia	Anowarul Haque Member		✓			
	Zahir Mistry		✓			
	Mahbulul Haque Sowdagar		✓			
	Bodiuzzaman Mistry		✓			
	Mojibul Haque Master		✓			
		Shafi Member			✓	
		Sheikh Ali Pandit	✓			
	Rafiqul Islam Muhuri			✓		
H&FW Centre Saherkhali	Monir Ahmed Fakir		✓			
	Mohammad Miah		✓			
	H&FW Centre		✓			
	Chowdhury Co.		✓			
	Ali Miah Chowdhury		✓			
	Hedu Boli				✓	
		West Saherkhali Cyclone Centre			✓	
	Kamal Majhi			✓		

Contd....

Worksheet for Planning
Phase-out of Satellite Clinics and EPI Outreach Sites within
the Community Clinic Catchment Area

Union: **Dhum**

Thana: **Mirsarai**

District: **Chittagong**

Community Clinic	EPI sites in the catchment area (in the house of)	Satellite Clinics (+EPI services) in the catchment area (in the house of)	To be continued for		Special arrangement/ remarks
			0 month	3-6 months	
West Hingooli Dhum	Mohajan Hat Health Centre			✓	
	Mokshed, BSc		✓		
	Rahimullah Sowdagar		✓		
	Banglabazar H&FWC		✓		
	Niamatullah Bhuiyan		✓		
	Ali Mia Sowdagar			✓	
		Dudu Mia		✓	
Mubarak Ghona		Monasir Sowdagar	✓		
	Enam Mollah		✓		
	Dakshin Mobarak Ghona Primary School		✓		
	Cyclone Shelter Centre		✓		
	Aju Kerani			✓	
	Haji Sheikh Alam		✓		
		Farazi Bari		✓	
H&FWC		Abul Quasem Chairman	✓		
		Idris Contractor	✓		
	Krishna Mohajan Bhuiyan			✓	
	Kazi Bari		✓		
	Bangla Bazar H&FWC		✓		
	Delwar Hussain Master		✓		
	Golaler Rahman Pandit		✓		
	Ali Amber Chowdhury		✓		
	Manuela Sowdagar		✓		
	Jinnat Ali Kamla		✓		

Contd....

Worksheet for Planning
Phase-out of Satellite Clinics and EPI Outreach Sites within
the Community Clinic Catchment Area

Union: **Paira**

Thana: **Abhoynagar**

District: **Jessore**

Community Clinic	EPI sites in the catchment area (in the house of)	Satellite Clinics (+EPI services) in the catchment area (in the house of)	To be continued for		Special arrangement/ remarks	
			0 month	3-6 months		
Samaspur	Family Welfare Centre			✓		
	Noor Mohammad Molla			✓		
	Md. Barik Mollah			✓		
	Md. Harez Khan			✓		
	Md. Jalil Sheikh			✓		
	Mohammad Ali		✓			
		Nani Gopal Biswas	✓			
	Md. Ismail Sardar		✓			
Barandi	Md. Monsur Gazi			✓		
	Md. Mobarak Mollah			✓	Project population segregated by water body	
	Muktar Mollick		✓			
	Nowab Ali Mollah			✓		
	Md. Akram Ali Mollah		✓			
		Lutfur Laskar		✓		
		Md. Amzad Sardar	✓			
	Kalipoda Roy	✓				
Dattagati	Sannashi Biswas			✓		
	Aboni Bushan Mondal		✓			
	Bikas Chandra Mondal		✓			
	Md. Amzad Mollah		✓			
	Kalipoda Mondal			✓		
		Pabitra Kumar Roy			✓	
		Mritrunjoya Sarker	✓			
	Abdul Rashid Molla	✓				

Contd....

**Worksheet for Planning
Phase-out of Satellite Clinics and EPI Outreach Sites within
the Community Clinic Catchment Area**

Union: **Baghutia**

Thana: **Abhoynagar**

District: **Jessore**

Community Clinic	EPI sites in the catchment area (in the house of)	Satellite Clinics (+EPI services) in the catchment area (in the house of)	To be continued for		Special arrangement/ remarks
			0 months	3-6 months	
	FWC			✓	
Baghutia Family Welfare Centre (FWC)		Dr. Yunus Ali	✓		
		Kanailal Dey	✓		
		Hazer Sarder		✓	
		Amzad Sikder	✓		
		Zamir Ali		✓	
Paikpara		Sheikh Akbar Ali	✓		
		Siddiq Biswas	✓		
		Hazari Lal Rishi		✓	Pocket population/culturally segregated pop.
		Mr. Alekuddin		✓	
		Kalipoda Rishi		✓	Pocket pop.
Singari		Mr. Shamsur Rahman	✓		
		Haji A Malek	✓		
		Mr. Bakkar Sheikh	✓		
		Kartik Chandra Biswas		✓	
		Nazrul Islam		✓	
		Mohadeb Biswas		✓	
Bivagdi		Sirajuddin		✓	
		Amir Ali		✓	
		Motleb Hossain		✓	
		Fazlul Haque	✓		
		Hashem Ali Sheikh	✓		
		Shibendra Nath Hore		✓	
		Karim Mollick	✓		

Chart A. Critical activities for implementation of the transition plan (Plan-A) on shift from outreach to CC-based service-delivery system

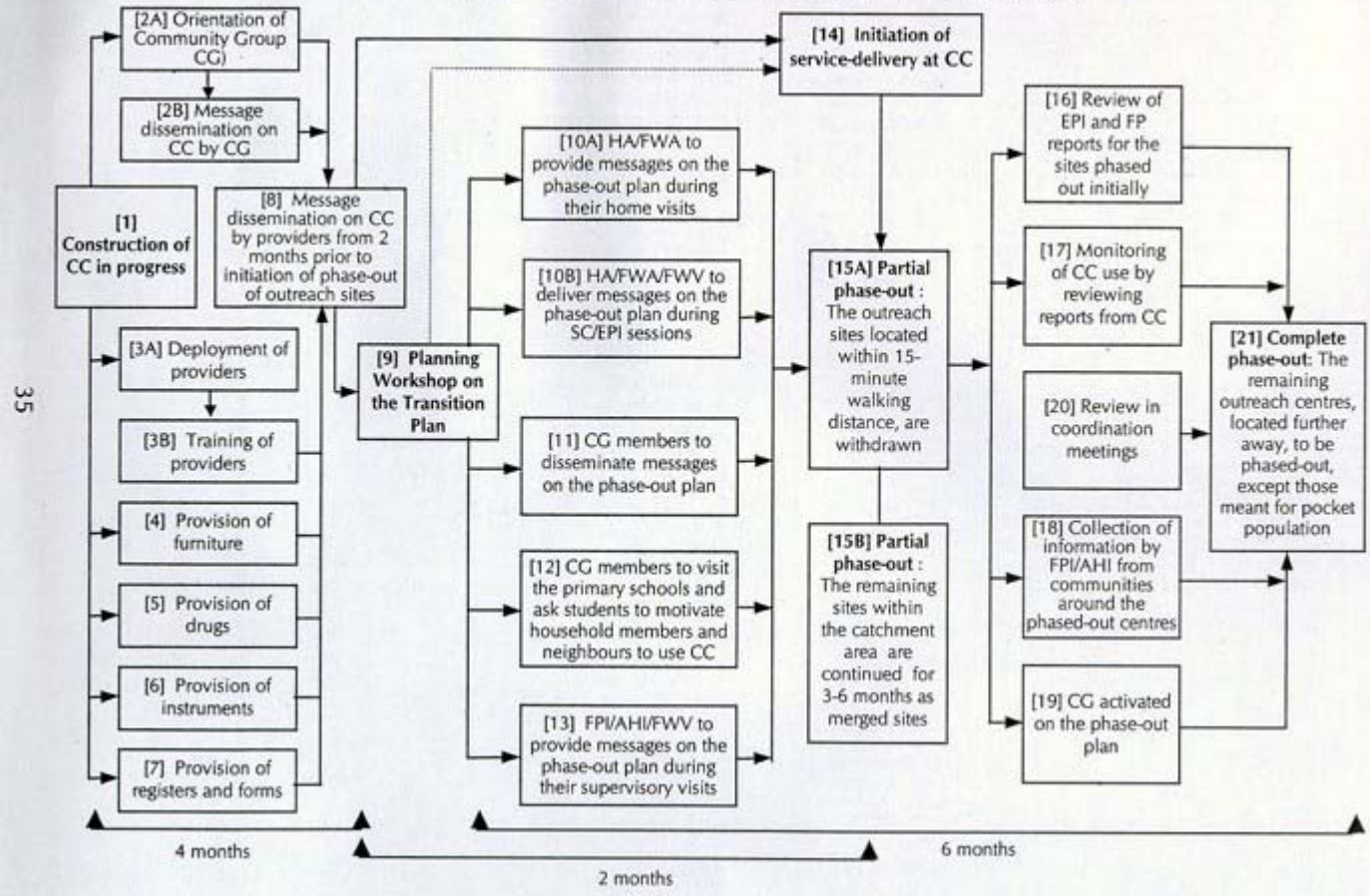

35

Annexure 5

Chart B. Critical activities for implementation of the transition plan (Plan-B) on shift from outreach to CC-based service-delivery system

