

A Modified Routine Analysis of Arsenic Content in Drinking-water in Bangladesh by Hydride Generation-Atomic Absorption Spectrophotometry

M.A. Wahed¹, Dulaly Chowdhury¹, Barbro Nermell², Shafiqul Islam Khan¹,
Mohammad Ilias¹, Mahfuzar Rahman¹, Lars Åke Persson³, and Marie Vahter²

¹Nutritional Biochemistry Department, Laboratory Sciences Division, ICDDR,B: Centre for Health and Population Research, GPO Box 128, Dhaka 1000, Bangladesh, ²Institute of Environmental Medicine, Karolinska Institutet, Stockholm, Sweden, and ³International Maternal and Child Health, Uppsala University, Uppsala, Sweden

ABSTRACT

The high prevalence of elevated levels of arsenic in drinking-water in many countries, including Bangladesh, has necessitated the development of reliable and rapid methods for the determination of a wide range of arsenic concentrations in water. A simple hydride generation-atomic absorption spectrometry (HG-AAS) method for the determination of arsenic in the range of $\mu\text{g/L}$ to mg/L concentrations in water is reported here. The method showed linearity over concentrations ranging from 1 to 30 $\mu\text{g/L}$, but requires dilution of samples with higher concentrations. The detection limit ranged from 0.3 to 0.5 $\mu\text{g/L}$. Evaluation of the method, using internal quality-control (QC) samples (pooled water samples) and spiked internal QC samples throughout the study, and Standard Reference Material in certain lots, showed good accuracy and precision. Analysis of duplicate water samples at another laboratory also showed good agreement. In total, 13,286 tubewell water samples from Matlab, a rural area in Bangladesh, were analyzed. Thirty-seven percent of the water samples had concentrations below 50 $\mu\text{g/L}$, 29% below the WHO guideline value of 10 $\mu\text{g/L}$, and 17% below 1 $\mu\text{g/L}$. The HG-AAS was found to be a precise, sensitive, and reasonably fast and simple method for analysis of arsenic concentrations in water samples.

Key words: Hydride generation-atomic absorption spectrophotometry; Arsenic; Tubewells; Drinking-water; Bangladesh

INTRODUCTION

Inorganic arsenic is highly toxic and is a documented human carcinogen (1,2). The presence of elevated concentrations of arsenic in groundwater is a serious public-health problem in many countries, including Bangladesh. Arsenic-containing bedrock, soil, and sediment are the major sources of arsenic in groundwater. Recent information indicates that many districts in Bangladesh have

arsenic levels exceeding the national standard of 50 $\mu\text{g/L}$ (3,4). More than 50 million people in Bangladesh are believed to be exposed to concentrations of arsenic in drinking-water above the WHO guideline of 10 $\mu\text{g/L}$ (5).

Various field-kits are available to identify elevated concentrations of arsenic in drinking-water, but, in most cases, those analyses are qualitative or semi-quantitative (6-10) as the concentration of arsenic in water is estimated from a colour-chart (11). They are not sensitive enough to measure low concentrations, i.e. below 10 $\mu\text{g/L}$. From a toxicological point of view, it is essential to obtain precise measures even at very low concentration. The risk of adverse health effects of arsenic increases even at very low concentrations of arsenic in drinking-water (12).

Correspondence and reprint requests should be addressed to: M.A. Wahed
Nutritional Biochemistry Department
Laboratory Sciences Division
ICDDR,B: Centre for Health and Population Research
GPO Box 128, Dhaka 1000
Bangladesh
Email: wahed@icddr.org
Fax: 880-2-8812529

For more exact determinations at low concentrations, various laboratory-based methods have to be used. In rural areas, it is common for families to have their own water source. It is, therefore, often necessary to screen large numbers of water samples. In Bangladesh alone, there are 6-10 million tubewells, many of which have elevated concentrations of arsenic in water (4). Many of the fast and sensitive laboratory methods, e.g. Inductively Couple Plasma Mass Spectrophotometry (ICP-MS), an expensive equipment with high running costs. The hydride generation-atomic absorption spectrophotometry (HG-AAS) is a suitable method for the analysis of concentrations of arsenic in water in most laboratories because of its high sensitivity, speed of analysis, and comparatively low cost (13-15).

We undertook an initiative to set up an HG-AAS method for routine analysis of total arsenic in drinking-water. In general, there is no need for speciation of inorganic arsenic in different oxidation states in water as trivalent arsenic (arsenite) may be oxidized to pentavalent arsenic upon storage, and this is rapidly reduced to trivalent arsenic in the body (16). The method was used for analyzing arsenic in more than 13,000 water samples within a project area aimed at determining the prevalence of arsenic in drinking-water and related skin lesions in Matlab, an arsenic-affected rural area in Bangladesh (17).

MATERIALS AND METHODS

Instrumentation

Concentrations of arsenic in water were determined with an HG-AAS (Shimadzu model AA-6800) connected to an auto-sampler (ASC-6100, Shimadzu) and a hydride generation system (HVG-1, Shimadzu). The spectrophotometer was operated at 193.7 nm with a slit width of 1.0 nm. The lamp current was 12 mA. The fuel acetylene (air-acetylene flame) flow rate was 2.0 litres per minute at a pressure of 0.9 kgf/cm² and the burner height of 7 mm. The flow rate of the argon carrier gas was 70 mL per minute at a pressure of 0.35 Mpa.

Reagents and chemicals

All the chemicals (BDH) used for the determination of arsenic were of analytical grade and were purchased from VWR International Ltd., UK. Water for the preparation of standards was distilled and de-ionized. All the chemicals were stored at room temperature. Working standards for arsenic were prepared daily from stock arsenic trichloride (AsCl₃) solution. Potassium iodide (KI) (20%) and hydrochloric acid (HCl) (37%) were used for reduction of arsenic (V). 0.4% sodium borohydride in 0.1% sodium hydroxide was prepared daily and kept at room

temperature during analysis. A standard solution of arsenic pentoxide (As₂O₅) was also used for checking the accuracy of the method.

Sample collection

Samples of water were collected from all functioning tubewells in Matlab during 2002-2003 by field research assistants as described elsewhere (17). Water was collected after about 30 strokes of the pump in 20-mL polyethylene vials to which 30 µL of 69% HNO₃ had been added (at the field laboratory prior to water collection) to acidify the water sample to a pH below 2 to prevent precipitation of iron and co-precipitation of arsenic (18). The vials were labelled and stored at -20 °C at the Matlab Health Research Centre until analysis at the Nutritional Biochemistry Laboratory of ICDDR,B in Dhaka.

Analysis by HG-AAS

Before HG-AAS analysis, 1 mL of 5 M HCl and 1 mL of 20% KI were added to a 10-mL water sample in a Pyrex test-tube and heated on a water bath at 80 °C for 30 minutes for the reduction of pentavalent arsenic (arsenic V) to trivalent arsenic (arsenic III). Blanks and standards were prepared in the same manner.

The KI-treated water samples were introduced into a continuous flow of 1 M HCl and 0.4% NaBH₄ (in 0.1% NaOH) in a reaction coil to generate the gaseous hydride by a peristaltic pump (Fig. 1). The arsine gas (from sodium borohydride and acid) so produced were then carried into a separator, in which the gas phase was separated from the liquid phase and was passed on to the absorption cell by argon gas, while the liquid phase was drained off. The absorption cell was heated by an air-acetylene flame to pyrolyze hydride to arsenic atoms. Background-corrected (continuous deuterium lamp) absorbance values were recorded, and the peak heights were used for quantitation using the wizAAard software (Shimadzu).

Solutions for a four-point standard curve (5, 10, 20, and 30 µg/L) were prepared from an intermediate AsCl₃ standard (1,000 µg/L), kept in a refrigerator. The standard curve was not linear beyond 30 µg/L, and samples exceeding that concentration were diluted and re-analyzed. The concentration of arsenic in those samples was determined by multiplying by the dilution factor, as applicable.

Analytical performance

Accuracy and precision of analyses were evaluated using the Standard Reference Water Material (SRM, 1643d) from the National Institute of Standards and Technology, USA, and 10 internal quality-control (QC) samples which were prepared from pooled water samples. Ten replicates

of the internal QC samples and the SRM were run in one lot, and the concentrations obtained against the standard curve are shown in Table 1. The internal QC samples were included in all analytical runs. During

addition, one standard (20 µg/L) was run after every seven samples to check for drifting. If the value of QC, including the recovery test, differed by less than 5%, the whole lot was repeated.

Fig. 1. Modified flow-chart of analysis of arsenic in drinking-water by hydride generation-atomic absorption spectrophotometry (printed with permission from Shimadzu). The moisture trap was developed in the present study

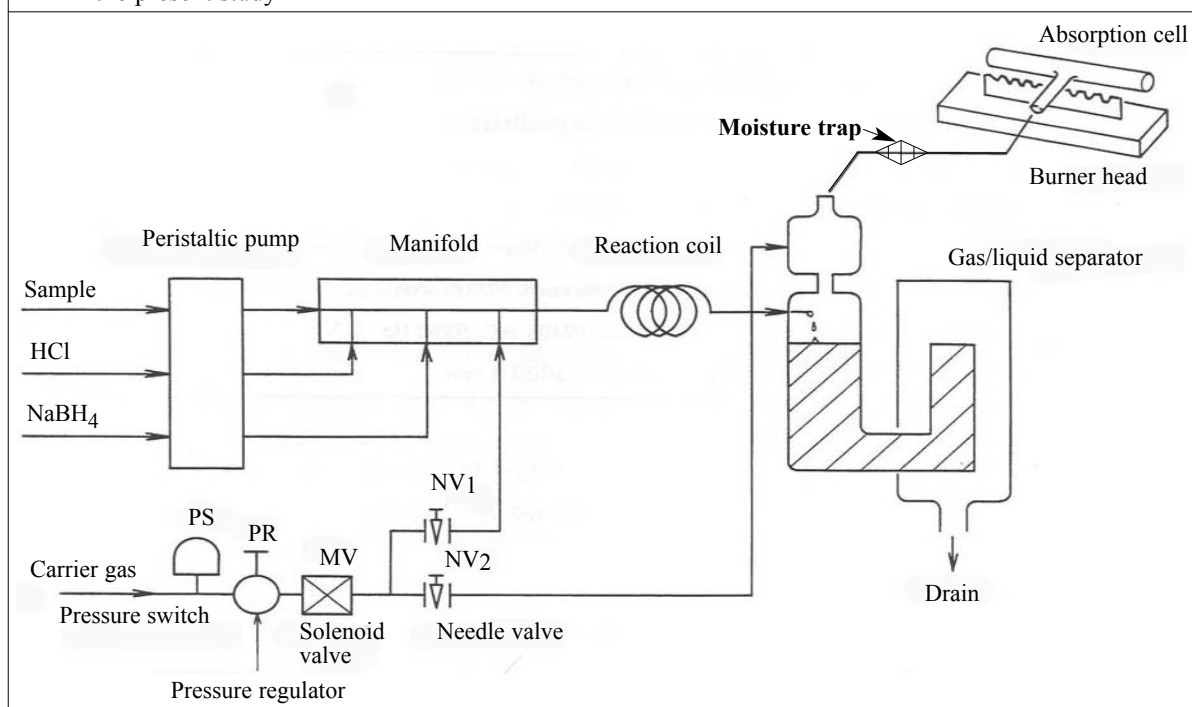

Table 1. Internal quality-control water samples for analysis of arsenic included in the present work

Sl. no.	No. of pooled samples	Obtained value evaluated on SRM	Within-run, ten replicates CV%	Between-run, CV%	Within-run for SRM
1	Pool-1 (n=14)	26.1±1.3	4.9	6.5	56±0.69 (certified value=56.02±0.76)
2	Pool-2 (n=25)	109±2.7	2.5	2.7	
3	Pool-3 (n=22)	24.1±0.9	3.7	4.8	
4	Pool-4 (n=20)	236±7.5	3.2	3.9	
5	Pool-5 (n=18)	29.5±0.95	3.2	4.7	
6	Pool-6 (n=20)	343±9.5	2.8	3.9	
7	Pool-7 (n=19)	30.6±1.1	3.6	4.2	
8	Pool-8 (n=18)	239±6.9	2.9	3.5	
9	Pool-10 (n=20)	28.3±1.1	3.9	4.5	
10	Pool-11 (n=21)	365±7.2	2.0	2.6	

CV=Coefficient of variation; SRM=Standard reference material

the study period, 10 different water samples were mixed to develop a pool. Such pool samples were prepared every three months. Pooled water samples of 26 µg/L spiked with known standards (10 and 20 µg/L) in the ratio of 1:1 were run as recovery test in every lot. In

The analytical performance was also evaluated by inter-laboratory comparison. In total, 221 water samples were collected in duplicate in the field and were analyzed at both ICDDR,B laboratory and Institute of Environmental Medicine (IMM), Karolinska Institutet, Stockholm.

The IMM used direct HG-AAS (Perkin Elmer 303, MHS-20) (19).

RESULTS

The detection limit, calculated as three times the standard deviation (SD) of the blank, varied between 0.3 and 0.5 $\mu\text{g/L}$ over the entire two-year period (192 days) of drinking-water analyses.

The analytical performance was evaluated by analyzing SRM over a two-year period. The within-run percent coefficient of variation (CV%), as assessed by analyzing the 10 internal QC samples 10 times each in one run, and the between-run CV%, as evaluated based on the SRM ($n=10$), are shown in Table 1. The standard 20 $\mu\text{g/L}$ of arsenic pentoxide was run two or three times in one lot. Our criteria for acceptance were 5% for higher concentrations and 10% for low concentrations. The CV% recovery experiment using the spiked standard was within 5 ($n=65$ for 10 $\mu\text{g/L}$ and $n=127$ for 20 $\mu\text{g/L}$).

The inter-laboratory comparison of analyses of arsenic in water showed a significant correlation between the results of the two laboratories ($r=0.84$) but fairly large discrepancies for certain samples. The samples with the largest differences ($n=41$) between the two laboratories were re-analyzed at the Karolinska Institutet. Some ($n=18$) of those water samples had precipitation of iron, and the pH was observed to be 3 to 5, indicating insufficient acid in the sample containers and precipitation of iron. As such, precipitation is likely to involve co-precipitation of arsenic (18); this may explain, in part, the erroneous arsenic results. The coefficient of correlation between the IMM and the ICDDR,B results, using re-analyzed data and excluding the 18 samples with elevated pH, was 0.95 (Fig. 2).

The modified HG-AAS method was used for analysis of concentrations of arsenic in water from 13,286 tubewells in Matlab. Distribution of arsenic concentrations obtained for the 13,286 water samples is shown in Table 2.

DISCUSSION

In this study, a sensitive continuous-flow HG-AAS method was modified and used for the determination of arsenic in drinking-water. The detection limit ranged between 0.3 and 0.5 $\mu\text{g/L}$ over more than 192 analytical runs that we carried out over a two-year period. Thus, the method is considerably more sensitive than the field tests. We found several advantages of the HG-AAS method compared to many other methods. The HG-AAS

method has few interferences, is reasonably sensitive and fast, and showed good reproducibility.

Several techniques have been developed for the generation of arsine using 1-4% NaBH_4 and 6-M HCl. We found that high concentrations of NaBH_4 and HCl adversely affected the signal to background ratio for arsenic and made the solutions highly corrosive. Concentra-

Fig. 2. Inter-laboratory comparison of analyses of 199 water samples at ICDDR,B and Karolinska Institutet

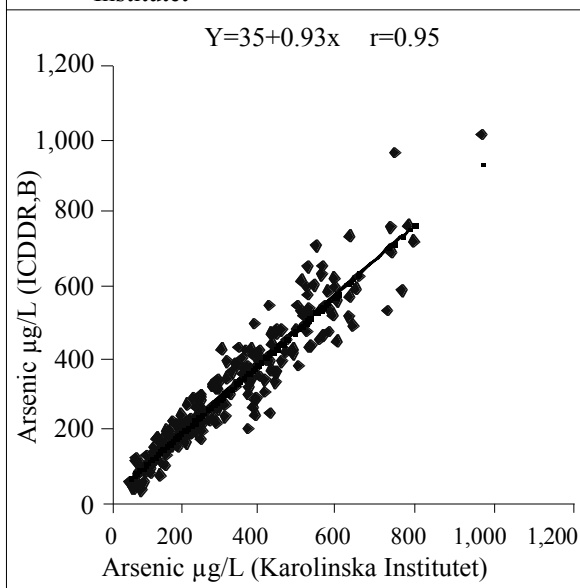

Table 2. Concentrations of arsenic ($\mu\text{g/L}$) in tubewell water in the Matlab study area

Arsenic concentration ($\mu\text{g/L}$)	No. of tubewells	Percentage of total
<1	2,235	16.8
1-4.9	1,179	8.9
5-9.9	380	2.9
10-49	1,099	8.3
50-149	1,471	11.1
150-299	3,021	22.7
300-499	2,651	20.0
500-999	1,192	9.0
1,000-1,999	56	0.4
$\geq 2,000$	2	0.02
Total	13,286	100

tions of NaBH_4 above 1% caused background drifting and increased the flame. High concentrations of NaBH_4 showed negative absorbance because of high amounts of hydrogen produced from the reaction of NaBH_4 with HCl. This affected the results, particularly at low concentrations. We found that the optimum concentration of

NaBH₄ and HCl for hydride generation was 0.4% and 1 M respectively, providing a detection limit of 0.3-0.5 µg/L.

A major problem was that moisture in the carrier gas accumulated and formed a thick layer inside the absorption cell. Because of this, a considerable time (2-3 hours per day) was required to optimize the cell temperature, leading to wastage of time and gases. White patches or scars formed rapidly in the absorption cell and which led to frequent breakage of the quartz glass cell. Therefore, we developed a moisture trap consisting of two narrow-pointed Pyrex glass tubes loosely filled with absorbent cotton wool. This substantially reduced the carry-over of moisture from the gas-liquid separator and markedly increased the duration of the expensive quartz absorption cell.

The method developed was successfully applied to measure concentrations of arsenic in water from 13,286 tubewells in Matlab. About 29% of the water samples had concentrations of arsenic of below 10 µg/L, the guideline recommended by WHO (5). About 37% of the water samples had concentrations of arsenic below 50 µg/L, the drinking-water standard in Bangladesh. Obviously, these concentrations would be difficult to measure correctly using the field-kit methods (6,8). We are currently evaluating the performance of the Merck field-kit for determination of arsenic in water, which has been extensively used for field analysis of arsenic in Bangladesh (20). Following field analysis of arsenic concentrations in water in Matlab, tubewells with arsenic concentrations in water below 50 µg/L were painted green, while those with concentrations exceeding 50 µg/L were painted red. This was the initial step in the ongoing arsenic mitigation programme, carried out in collaboration with BRAC, a non-governmental organization in Bangladesh (20). With a more precise and accurate, but still simple and rapid laboratory method, like the present HG-AAS method, the indication of 'safety' might have been more reliable.

The observed precipitation and elevated pH in some water samples emphasize the need for proper acidification of water samples collected for analysis of arsenic. Arsenic in shallow-tubewell water in Bangladesh is often accompanied with iron (4,19). Unless water samples are appropriately acidified (pH below 2), there is a risk for precipitation of iron and co-precipitation of arsenic (18), which may result in falsely low or high concentration of arsenic, depending on the presence of precipitates in the sub-sample taken for analysis and dissolution during the analytical process.

The main disadvantage of the method was that the standard curve was non-linear beyond 30 µg/L. Thus, the water samples with arsenic concentrations of more than 30 µg/L had to be diluted manually and re-analyzed. As concentrations of arsenic in the water samples from tubewells under investigation ranged up to several mg/L, dilution factors up to 150 had to be applied to bring down the analytical signal within the linear range of the calibration curve. We performed repeated analyses of samples with high dilution factors and found the precision to be acceptable (CV <5%). The limited operating range of the HG-AAS method is particularly problematic when analyzing samples from areas with high and varying concentrations of arsenic in water, such as those found in the present study. In the case of varying concentrations of arsenic with repeated analyses after dilution, we managed to analyze 60 samples per day, while as many as 80 water samples could be analyzed per day at low concentrations of arsenic.

The HG-AAS method for the determination of concentrations of arsenic at µg/L in drinking-water proved to be reasonably fast, simple, cost-effective, and sensitive. The method is suitable for analyzing concentrations of arsenic in large numbers of water samples with a high degree of accuracy and precision.

ACKNOWLEDGEMENTS

The study was conducted at ICDDR,B: Centre for Health and Population Research with support from the Swedish International Development Agency (Sida), World Health Organization (WHO), and the United States Agency for International Development (USAID). The HG-AAS instrument was purchased with the WHO grant.

REFERENCES

1. International Agency for Research on Cancer. Some drinking-water disinfectants and contaminants, including arsenic. Lyon: International Agency for Research on Cancer, 1980;23:39-141.
2. World Health Organization. Arsenic and arsenic compounds. Geneva: World Health Organization, 2001. 521 p. (Environmental health criteria no. 224).
3. Alam MG, Allinson G, Stagnitti F, Tanaka A, Westbrooke M. Arsenic contamination in Bangladesh groundwater: a major environmental and social disaster. *Int J Environ Health Res* 2002;12:235-53.
4. British Geological Survey. Arsenic contamination of groundwater in Bangladesh. Keyworth: British Geological Survey, 2001;2:WC/00/19.

5. World Health Organization. Guidelines for drinking-water quality. 2d ed. Geneva: World Health Organization, 1996;2:158-62.
6. van Geen A, Cheng Z, Seddique AA, Hoque MA, Gelman A, Graziano JH *et al.* Reliability of a commercial kit to test groundwater for arsenic in Bangladesh. *Environ Sci Technol* 2005;39:299-303.
7. Deshpande LS, Pande SP. Development of arsenic testing field kit—a tool for rapid on-site screening of arsenic contaminated water sources. *Environ Monit Assess* 2005;101:93-101.
8. Khandaker NR. Limited accuracy of arsenic field test kit (abstract). *Environ Sci Technol* 2004;38:479A.
9. Rahman MM, Mukherjee D, Sengupta MK, Chowdhury UK, Lodh DC, Roy S *et al.* Effectiveness and reliability of arsenic field testing kits: are the million dollar screening projects effective or not? *Environ Sci Technol* 2002;36:5385-94.
10. van Geen A, Protus T, Cheng Z, Horneman A, Seddique AA, Hoque MA *et al.* Testing groundwater for arsenic in Bangladesh before installing a well. *Environ Sci Technol* 2004;38:6783-9.
11. Merck kit. Darmstadt: Merck KGaA.
12. National Research Council. Arsenic in drinking water: 2001 update. Washington, DC: National Academy Press, 2001. 244 p.
13. Hershey JW, Oostdyk TS, Keliher PN. Determination of arsenic and selenium in environmental and agricultural samples by hydride generation atomic absorption spectrometry. *J Assoc Off Anal Chem* 1988;71:1090-3.
14. Norin H, Vahter M. A rapid method for the selective analysis of total urinary metabolites of inorganic arsenic. *Scand J Work Environ Health* 1981;7:38-44.
15. Sakamoto H, Susa Y, Ishiyama H, Tomiyasu T, Anazawa K. Determination of trace amounts of total arsenic in environmental samples by hydride generation flow injection-AAS using a mixed acid as a pretreatment agent. *Anal Sci* 2001;17:1067-71.
16. Vahter M, Norin H. Metabolism of ⁷⁴As-labeled trivalent and pentavalent inorganic arsenic in mice. *Environ Res* 1980;21:446-57.
17. Rahman M, Vahter M, Wahed MA, Sohel N, Yunus M, Streatfield PK *et al.* Prevalence of arsenic exposure and skin lesions. A population based survey in Matlab, Bangladesh. *J Epidemiol Community Health* 2006;60:242-8.
18. Clesceri LS, Arnold E, Greenberg R, Rhodes T. Standard methods for the examination of water and wastewater. 17th ed. Washington, DC: American Public Health Association, 1989:3010B.
19. Vahter M, Friberg L, Rahnster B, Nygren A, Nolinder P. Airborne arsenic and urinary excretion of metabolites of inorganic arsenic among smelter workers. *Int Arch Occup Environ Health* 1986;57:79-91.
20. Jakariya M, Rahman M, Chowdhury AMR, Rahman M, Yunus M, Bhiuya A, Wahed MA *et al.* Sustainable safe water options in Bangladesh: experiences from the Arsenic Project at Matlab (AsMat). *In: Bundschuh B, Shekharam C, editors. Natural arsenic in groundwater: occurrence, remediation and management.* London: Taylor & Frances, 2005:319-30.